

# W|ECO® FOLDING-SKID ARROW BOARDS

MODEL WSSP  
PRODUCT SPECIFICATIONS | OCTOBER 2014

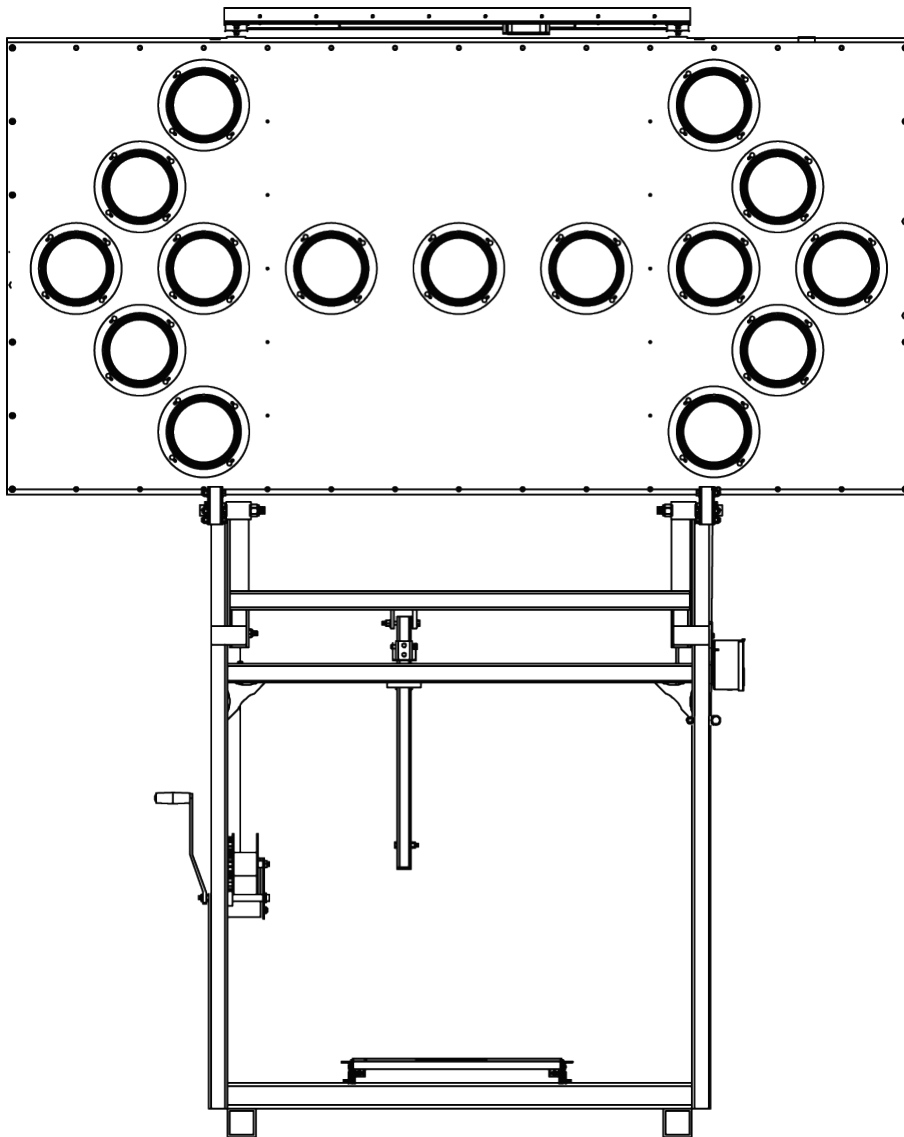

## 1. DESCRIPTION

1.1. Description Arrow boards direct traffic by flashing a brightly lit arrow pattern on a large, highly visible display panel. Wanco® Skid-Mount Arrow Boards can be affixed to a truck bed or any rigid footing. The folding skid features a display panel that pivots up to the vertical position when deployed, and down to the horizontal position for transport or storage. The display is held in place with a single support for ease of use.

Wanco Folding-Skid Arrow Boards are self-powered, requiring no wiring to an external power supply. The control panel may be installed inside the truck cab or outside on the arrow board frame. Arrows and other patterns are selected by the user.

Wanco skid-mounted arrow boards feature W|ECO® technology, a highly efficient power system. With Wanco's exclusive LED lamps and small, eco-friendly batteries, W|ECO arrow boards are extremely energy-efficient without sacrificing performance. Power is provided by batteries, which are charged by an automated solar charging system. With sufficient sunlight, W|ECO arrow boards can run indefinitely without intervention.

1.2. Models

1.2.1. Standard skid	WSSP55-LSA	Arrow-board with 15-light display panel
	WSSP55-LSAC	Arrow-board with 25-light display panel
1.2.2. Low-profile skid	WSSP55-LSA(LP)	Arrow-board with 15-light display panel
	WSSP55-LSAC(LP)	Arrow-board with 25-light display panel

## 2. FEATURES

- 2.1. Operation
- High-output amber LEDs
  - Selection of arrow and other display patterns
  - Easy to operate and maintain
  - Heavy-duty hand-winch with safety brake allows one person to raise board
  - Single locking device holds arrow board in place while operating and during transport
  - Controller can be located inside truck cab
  - Control box outputs have short-circuit protection, helping prevent blown transistors
  - Arrow display has automatic dimming
  - Meets MUTCD
- 2.2. Power system
- Energy-efficient operation results in long run times
  - Solar panels charge batteries automatically without intervention
  - System disconnects solar charging system from batteries when they are fully charged, preventing over-charging and damage to batteries
  - Unique system allows battery charging with solar panels or commercial power
  - Power system includes reverse polarity protection and low-voltage disconnect circuit
  - Controller has resettable fuses
  - Solar charging system features solid state voltage regulator with charge indicator

- 2.3. Maintenance
  - Sealed batteries are 100% maintenance-free
  - Durable powder-coat finish resists the elements
  - In travel position, unique design supports board without rear braces, reducing possibility of damage during transport or storage
  - Lamps and visors are easily replaced
  
- 2.4. Environmental
  - Consumes 80% less power than traditional solar arrow boards
  - Smaller batteries have 80% less lead content
  - Sealed batteries will not leak or spill
  - Decreased charging time saves energy and downtime
  - Manufacturing process emits near-zero VOCs
  - Nearly every component can be recycled
  
- 2.5. Application
  - Common applications include:
    - Roadwork zones
    - Road striping convoys
    - Road sweeping convoys
    - Pothole repairs
    - Crash cushion (TMA) trucks

### 3. DISPLAY

- 3.1. Display panel
  - 3.1.1. Description
    - Weather-resistant cabinet provides a rigid platform for LED lamps
  - 3.1.2. Size
    - 48" x 96" x 3" (122 x 244 x 8cm)
  - 3.1.3. Construction
    - Outer frame constructed of aluminum channel, 3" x 1" x 1/8" thick. Two interior channels add strength and prevent distortion of front and rear panels. All channel joints are welded.
    - Front and rear panels constructed of aluminum sheet, 5052-H32, 0.062" (1.575mm) thick. Panels are riveted and screwed to frame and interior channels.
  - 3.1.4. Finish
    - Oven-baked, flat-black (10% gloss), powder-coat finish ensures durability and corrosion protection. Panel assembly is high-pressure phosphate-washed prior to finish coat.
  - 3.1.5. Wiring
    - Weatherproof wiring between solar panel, control box, and display panel is P-clamped to trailer frame
  - 3.1.6. Storage
    - When lowered for storage and transport, the display panel is held in place without rear braces. As a result, the panel never strikes another surface during transport, eliminating damage that might otherwise occur (such as abrasion, deformation, and warping).

### 3.2. Front lights

3.2.1. Description	Display lights are laid out across the front face of the display panel. The layout allows for a variety of arrows and other patterns to appear depending on which lights are lit. The desired pattern is selected by the operator, using the arrow board controls.	
3.2.2. Type	PAR 46 LED lamp, 5¾" (14.5cm) dia.	
3.2.3. Wattage	<1.0W per lamp	
3.2.4. Voltage	8.0Vdc	
3.2.5. Light output	1425 lux per lamp	
3.2.6. Reverse-polarity protection	Protects lamps if control box wiring is connected backwards (which sometimes happens after servicing)	
3.2.7. LEDs	Technology	AllInGaP II (aluminum indium gallium phosphide) technology, T-1¾ size
	Color range	Amber, 590 to 593 nm
	Forward voltage	2.0 to 2.1Vdc @ 20mA
	Temperature limits	Operating temperature, -22 to 185°F (-30 to 85°C)
3.2.8. Lens	Function	Each lamp has an integrated hex lens that enhances the brightness and angularity of each LED while reducing power consumption
	Material	Acrylic
	Beam angle	Horizontal: 16.8 degrees, ±8.4 degrees Vertical: 9.5 degrees, ± 4.75 degrees  Angle determined by 10% of peak candle power (certified by independent testing laboratory)
3.2.9. Visor	Function	Each lamp is shrouded by a visor that enhances visibility by shading the lamp and preventing glare
	Material	High-impact ABS plastic
	Mounting	Four keyed slots enable visor to be removed from the display panel without removing screws
3.2.10. Visibility	4800 ft. (1463m)	

- 3.2.11. Legibility Daytime, 4800 ft. (1463m)  
Nighttime, 2400 ft. (732m)
- 3.2.12. Angularity 26.8 degrees @ 105 ft. (32m)  
54.0 degrees @ 49 ft. (15m)  
Total viewing area
- 3.2.13. Auto-dimming A photocell detects ambient light; the controller adjusts the brightness of the LEDs accordingly, dimming display brightness in darkness, increasing to full brightness in daylight  
  
Photocell location determined by control box location:  
  
Interior control box Photocell located on bottom of arrow board display, facing downward  
  
Exterior control box Photocell located inside control box, facing downward
- 3.2.14. Replacement Lamps can be replaced in less than two minutes. The only tool needed is a Philips screwdriver.
- 3.3. Rear lights
- 3.3.1. Description Two indicator lights on the back of the display panel suggest the current arrow board function to an operator located behind the arrow board by flashing a corresponding pattern
- 3.3.2. Type Sealed 2-diode LED light, surface-mount, 2½" x ¾" (6.6 x 1.9cm) lens  
  
See "Options and Optional Equipment" for rear light options
- 3.3.3. Wattage 0.9W
- 3.3.4. Voltage 8.0Vdc
- 3.4. Standards Meets MUTCD Part VI, Traffic Control for Street & Highway Construction and Maintenance Including Utility and Emergency Operations, Section 6F.53  
  
MUTCD Type C

#### 4. CONTROLLER

- 4.1. Function Allows operator to choose an arrow or other display pattern. Keeps the batteries fully charged while protecting them from deep discharge and overcharging. Maintains display flash-rate and controls automatic dimming.
- 4.2. Control box User-specified location determines control box type:  
Interior (truck cab) mount for permanent skid installations (best for tamper resistance)  
Exterior (skid frame) mount for temporary skid installations (best for portability)
- 4.2.1. Interior mount
- |           |                                                                                                                                                                                                                                                    |
|-----------|----------------------------------------------------------------------------------------------------------------------------------------------------------------------------------------------------------------------------------------------------|
| Location  | User-installed under dashboard inside truck cab                                                                                                                                                                                                    |
| Enclosure | Aluminum sheet construction, brushed aluminum finish                                                                                                                                                                                               |
| Wiring    | 30-foot cable with wiring harness and locking collar; hard-wired inside battery box, user-connected to back of control box after routing from battery box to inside truck cab<br><br>See "Options and Optional Equipment" for cable length options |
- 4.2.2. Exterior mount
- |                  |                                                                                                                                                                                                           |
|------------------|-----------------------------------------------------------------------------------------------------------------------------------------------------------------------------------------------------------|
| Location         | Factory-installed on right (passenger-side) upright of skid frame. Can be installed remotely from frame if specified prior to order.<br><br>See "Options and Optional Equipment" for cable length options |
| Enclosure        | Aluminum sheet construction, brushed aluminum finish<br><br>Hinged weatherproof cover with slam-latch<br><br>Hole in cover accepts customer-supplied padlock                                              |
| Cable protection | Molded plastic cover attached to back of control box, protects external wiring connections and can be removed for access to connectors; all wiring has quick-connect plugs                                |
- 4.2.3. Serviceability Entire control box is removable for easy exchange and factory servicing
- 4.3. Control panel
- 4.3.1. Display switch Toggle switch for turning arrow board display on and off
- 4.3.2. Display pattern selection Rotary switch; operator simply points the switch at the desired display pattern, which is silkscreened onto the front of the control panel
- 4.3.3. LED indicators Indicates the following status conditions:  
Low voltage (battery charging required)  
Low battery voltage detected, power shutdown occurred  
Solar charging system is charging batteries  
Batteries are fully charged

#### 4.4. Display patterns

4.4.1. All models All arrow boards can display any of the following 7 patterns (for samples, see Exhibit A):

Flashing arrow, left or right	10 lights total 5 lights form arrowhead 5 lights form stem
Flashing double arrow	13 lights total 5 lights form each arrowhead 3 lights form stem
Flashing four-corner warning	4 lights total 1 light at each corner
Flashing caution-bar warning	7 lights form horizontal bar across center of display panel
Sequencing stem with arrow, left or right	10 lights total 5 lights form arrowhead 5 lights form full stem  1st pulse: 2 far stem lights 2nd pulse: 4 far stem lights 3rd pulse: full arrow shape 4th pulse: blank display

4.4.2. 25-light models In addition to the 7 patterns described above, 25-light arrow boards can also display any of the following 5 patterns (for samples, see Exhibit A):

Sequencing arrow, left or right	10 lights total 5 lights form arrowhead 5 lights form full stem  1st pulse: 2 far stem lights with arrowhead 2nd pulse: 3 far stem lights with arrowhead 3rd pulse: full arrow shape 4th pulse: blank display
Sequencing chevron arrows, left or right	15 lights total 5 lights form each arrowhead  1st pulse: 1 far arrowhead 2nd pulse: 2 far arrowheads 3rd pulse: 3 arrowheads 4th pulse: blank display

Alternating diamonds  
16 lights total  
8 lights form each diamond  
1st pulse: 1 diamond shape on left  
2nd pulse: 1 diamond shape on right

4.5. Electronics

4.5.1. Location Inside control box

4.5.2. Temperature limits Operating temperature: -40 to 176°F (-40 to 80°C)

4.5.3. Flash rate 30 to 40 per minute, all display patterns

4.5.4. Positive drive circuit Positive power applied to lamps only when lit  
Negative is chassis grounded

4.5.5. Fuse protection Dual PTC resettable fuses

4.5.6. Reverse-polarity protection Protects the controller if battery cables are connected backwards (which sometimes happens after servicing)

4.5.7. Low-voltage disconnect Low-voltage-disconnect circuit engages when battery voltage drops to 11.2Vdc, shutting down power to protect batteries from full discharge

**5. SKID FRAME**

5.1. Construction All welded structural steel

5.2. Uprights Two uprights support display panel, reinforced by 23" structural steel gussets

5.3. Mounting Four mounting brackets welded to bottom of frame, each includes a through-hole for attaching to truck bed or rigid footing

5.4. Finish

5.4.1. Prewash Assemblies are run through a five-stage, high-pressure phosphate-wash prior to finish coat

5.4.2. Coating Frame is coated with oven-baked, safety-orange powder-coat finish to ensure durability and corrosion protection

See "Options and Optional Equipment" for color options

5.4.3. Salt spray resistance 1000 hours (ASTM Method B117) with <math>\frac{1}{8}</math>" (<math><3.18\text{mm}</math>) creep from scribe

5.4.4. Q.U.V. exposure 500 hours QUV-B (ASTM Method D4587-05) >75% gloss retention



5.5. Winch assembly

- 5.5.1. Function Hand-operated winch raises and lowers display panel
- 5.5.2. Capacity 1500 lbs. (680kg)
- 5.5.3. Brake Safety friction-brake prevents display panel from falling if operator loses grip on winch handle
- 5.5.4. Cable 1/4" (6.35mm) diameter galvanized aircraft cable

5.6. Slide-bar assembly

- 5.6.1. Function Locks display panel in place, ensuring panel cannot fall even if winch or cable were to fail. Slides up and down inside sleeve when winch is operated.  
  
Located off-center on upper crossbar between uprights. Sleeve is mounted to crossbar. Slide-bar is mounted to back of display panel.
- 5.6.2. Locking pin One 3/8" (0.95cm) wire lock pin holds slide bar and display panel in deployed or travel position. A lanyard ties the pin to the trailer frame.
- 5.6.3. Material Perforated 1 3/4" sq. steel tube, 12ga wall, zinc plated

**6. POWER SYSTEM**

- 6.1. Description Electronics powered by batteries, which are charged automatically with integrated solar charging system
- 6.2. Battery box
  - 6.2.1. Function Holds batteries and optional remote charger
  - 6.2.2. Construction Riveted all-steel construction, cover is bolted in place  
  
Removable panel on side of battery box provides access to optional remote charger  
  
All parts powder-coated before assembly
  - 6.2.3. Mounting Bolted to base of skid
- 6.3. Batteries
  - 6.3.1. Type Leak- and spill-proof valve-regulated lead acid (VRLA)  
  
See "Options and Optional Equipment" for battery options
  - 6.3.2. Features 100% maintenance-free  
  
Sealed and spill-proof  
  
Faster recharge and greater freeze resistance than conventional batteries  
  
Smaller and lighter-weight than conventional batteries  
  
Contains 80% less lead when compared to conventional batteries

- 6.3.3. Quantity Two
- 6.3.4. Voltage 12Vdc each
- 6.3.5. Weight 12.5 lbs. (6kg) each
- 6.3.6. Capacity 50 Ah total @ 12Vdc
- 6.4. Solar
  - 6.4.1. Panels One high-efficiency multi-crystal photovoltaic solar module
  - 6.4.2. Location Above display panel, no shadowing effect on any skid component. Articulated supports ensure solar array remains flat for continuous charging regardless of display panel position.
  - 6.4.3. Power output 50W  
See "Options and Optional Equipment" for solar options
  - 6.4.4. Current 2.89A max. system current  
3.22A open short-circuit current
  - 6.4.5. Voltage 17.3Vdc max.  
21.6Vdc open short-circuit voltage
  - 6.4.6. Regulation Solar panels regulated by arrow board controller
  - 6.4.7. Security Solar panel bolted to mounting frame with security screws and special security nut

## 7. DIMENSIONS & WEIGHT

### 7.1. Dimensions

#### 7.1.1. Standard skid

*inches  
(cm)*

**Travel position**

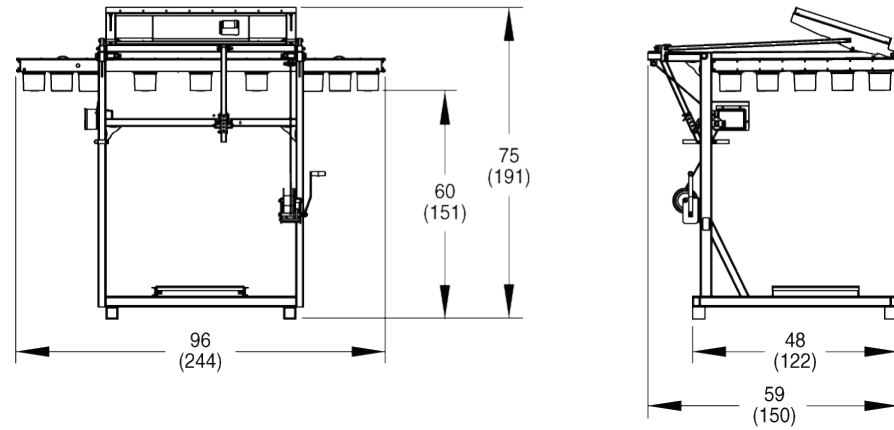

**Deployed**

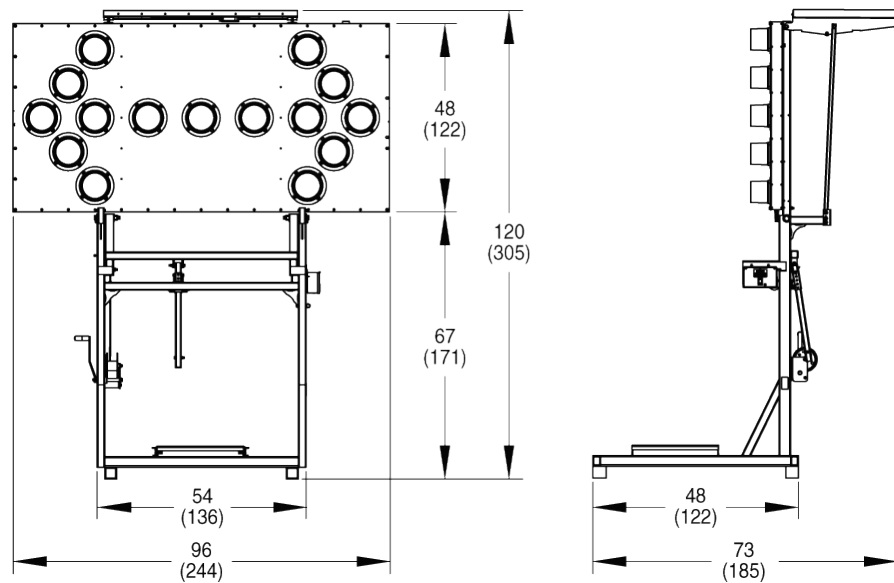

7.1.2. Low-profile skid

*inches  
(cm)*

**Travel position**

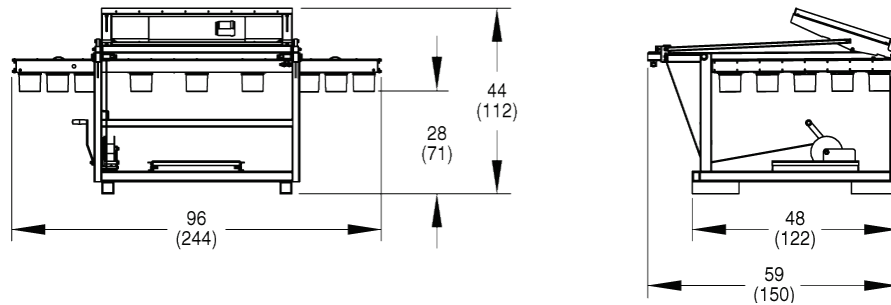

**Deployed**

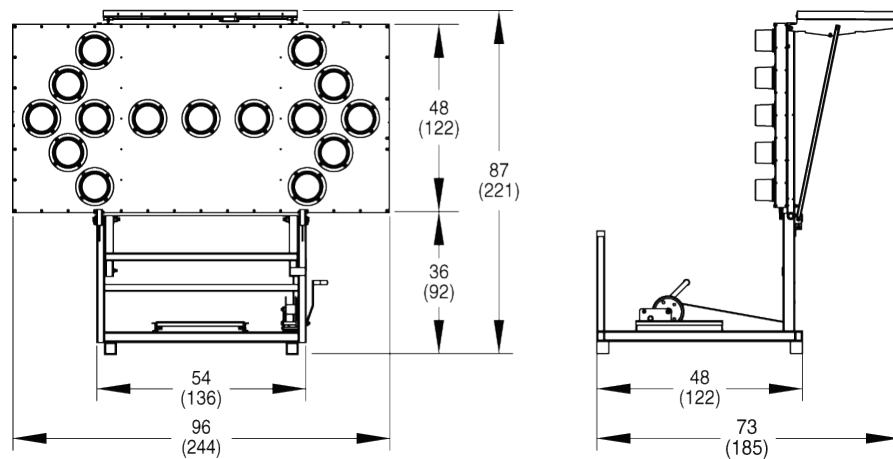

7.1.3. Mounting holes

*inches  
(cm)*

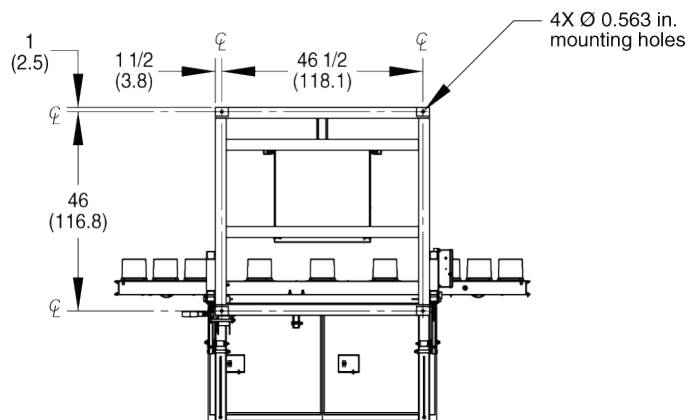

7.2. Weight

7.2.1. Standard skid      Approx. 540 lbs. (245kg)

7.2.2. Low-profile skid      Approx. 520 lbs. (236kg)

## 8. OPTIONS AND OPTIONAL EQUIPMENT

### 8.1. Power

- 8.1.1. Additional batteries For geographic locations with less solar charging potential or colder weather, and for applications that require year-round charging, add batteries for greater capacity
- |                        |                                                                                                                             |
|------------------------|-----------------------------------------------------------------------------------------------------------------------------|
| Options                | One additional VRLA 12Vdc battery in standard battery box, 24Ah additional capacity                                         |
|                        | Two additional VRLA 12Vdc batteries in large battery box, 48Ah additional capacity                                          |
|                        | Three additional VRLA 12Vdc batteries in large battery box, 72Ah additional capacity                                        |
| Large flat battery box | Large, flat battery box is required when the arrow board has more than three W ECO batteries; replaces standard battery box |
|                        | Bolted to base of skid                                                                                                      |
|                        | Riveted all-steel construction, cover is bolted in place                                                                    |
|                        | All parts powder-coated before assembly                                                                                     |
- 8.1.2. Deep-cycle batteries Replace W|ECO batteries with deep-cycle batteries. Requires replacing standard battery box with larger box.
- |                   |                                                                                                                  |
|-------------------|------------------------------------------------------------------------------------------------------------------|
| Options           | Two Group 24 deep-cycle 6Vdc batteries, wired in parallel and series for a 12-volt system, 315Ah total capacity  |
|                   | Four Group 24 deep-cycle 6Vdc batteries, wired in parallel and series for a 12-volt system, 630Ah total capacity |
| Weight            | Approx. 60 lbs. (26kg) each                                                                                      |
| Large battery box | Replaces standard battery box                                                                                    |
|                   | Riveted all-steel construction                                                                                   |
|                   | Bolted to base of skid                                                                                           |
|                   | All parts powder-coated before assembly                                                                          |
|                   | Divider panel inside box separates batteries from charger                                                        |
|                   | Louvers provide ventilation                                                                                      |
|                   | Latches keep cover closed and can accept user-supplied padlocks                                                  |

8.1.3. Remote charger	Function	Plugs into a standard commercial power source to recharge batteries if battery voltage drops due to lack of sun for automated solar charging system
	Type	12-volt battery charger
	Location	Inside battery box
	Smart charger	Three-stage smart-charging circuit keeps batteries fully charged, and will not overcharge batteries, which helps to ensure the longest possible battery life
	Output capacity	2A
	Output voltage	14.4Vdc nominal 13.0Vdc nominal float voltage
	Input voltage	90 to 132Vac, standard two-prong plug
	Frequency	50 to 60 Hz
8.1.4. Solar		For geographic locations with smaller solar charging potential, and for applications that require a year-round charging system, additional solar power is available  Options include 85W, 100W solar arrays; contact factory for details
8.2. Cable length		Custom cable lengths are available for mounting control box remotely from skid; contact factory for details
8.3. Finish color		Specify power-coat color and, if applicable, color scheme
8.4. Manual dimming		Substitute control box with manual dimming control for standard control box
8.5. Rear lights		Replace standard rear lamps with PAR 36 LED lamps, 4.5" (11.5cm) dia.

**EXHIBIT A: DISPLAY PATTERNS**

**Flashing patterns**

Pulse 1	Pulse 2	
		Flashing arrow, left or right
		Flashing double arrow
		Flashing four-corner warning
		Flashing caution-bar warning

**Sequential patterns**

Pulse 1	Pulse 2	Pulse 3	Pulse 4	
				Sequencing arrow, left or right
				Sequencing stem arrow, left or right*
				Sequencing chevron arrows, left or right*
				Alternating diamonds*

*\*Available only on 25-light arrow board models*